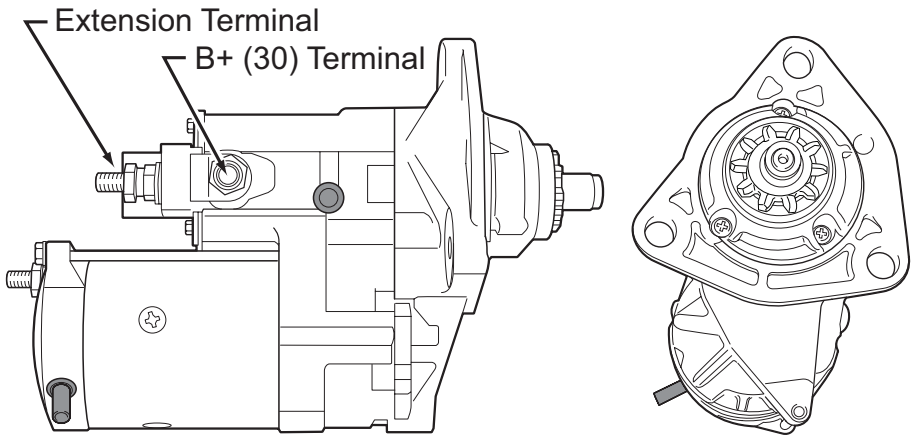


# R5 Heavy Duty Starter

## Installation Instructions



**Part No. 428000-445#**

Thank you for purchasing a DENSO R5 Gear Reduction Heavy Duty Starter. The drive end housing is fixed in position. There are different part numbers that fit different applications.

**Before installing this R5 Heavy Duty Starter, read these instructions completely.**

There may be different configurations of starter to engine mounting positions. These instructions are for general installation guidance.

**Refer to service information DSCA publication no. LA990009-1893.2-H before installation.**

### Definition of Terms

- ⚠WARNING:** Describes precautions that should be observed in order to prevent injury or death to the user during installation.
- ⚠CAUTION:** Describes precautions that should be observed in order to prevent damage to the vehicle or its components, which may occur during installation if sufficient care is not taken.
- NOTE:** Provides additional information that facilitates installation work.

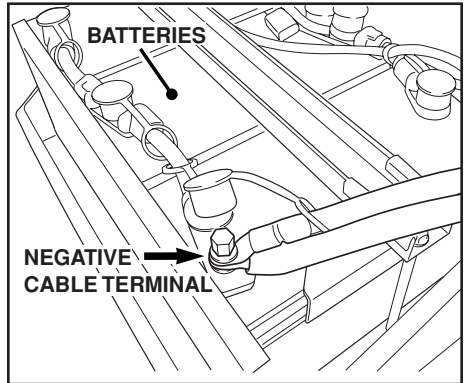
**⚠WARNING:** Always wear eye protection before performing any mechanical repairs to a vehicle.

## Original Starter Removal Instructions

1. Identify each wire & note the connection locations on the starter.
2. Disconnect and remove the battery cable from the starter.
3. Disconnect and remove all other wires from the starter.
4. Loosen all mounting hardware.
5. While supporting the starter, loosen and remove all mounting bolts and hardware that secure it to the flywheel housing, and remove the starter from the vehicle.

**⚠WARNING:** Disconnect the negative (-) or ground cable terminal from the battery(s). Failure to follow this step could result in personal injury and/or electrical system damage.

**NOTE:** If a spacer (or flange) is used on original starter, reuse for new starter installation.



**Fig. 1**

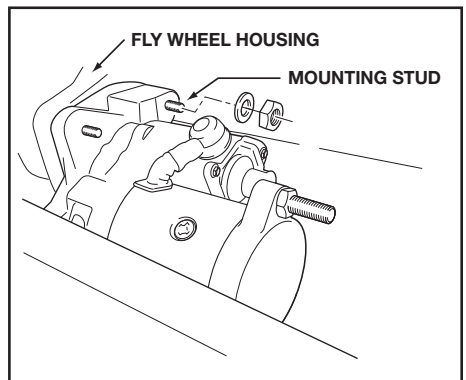
## Ring Gear Inspection

1. Inspect the ring gear for badly burred or damaged teeth. Rotate the engine with a pry bar or by other means to observe all the ring gear teeth.
2. Replace any ring gear with extremely damaged or worn teeth.

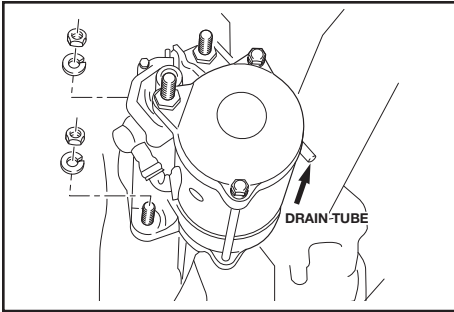
**NOTE:** Use of a damaged ring gear may result in no starter pinion engagement or premature pinion wear.

## DENSO Starter Installation Instructions

1. Slide the drive end housing into the fly wheel housing (See Fig. 2).
2. Align all mounting studs with the starter front housing mounting holes.
3. Secure the starter in place with one original mounting nut.

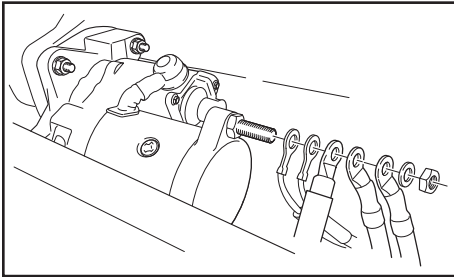


**Fig. 2**



**Fig. 3**

4. The placement of the drain tube should not be more than 15° from the downward position (See Fig. 3).
5. Support the starter and install the remaining original mounting nuts.
6. Torque the mounting nuts to the specifications of the applicable OEM service manual.
7. The drain plug should always point downward.

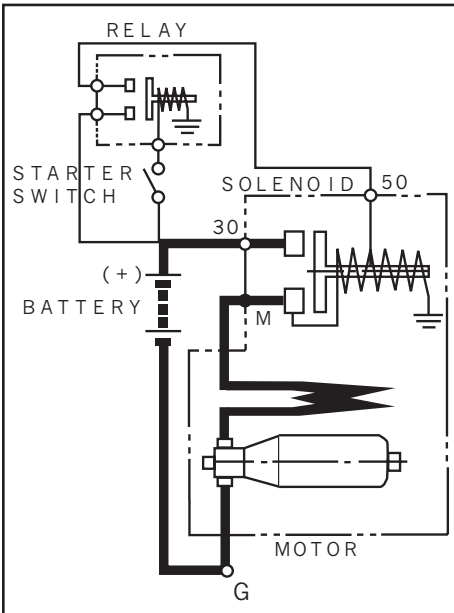


**Fig. 4**

Connect all required cabling and nuts to the ground stud (See Fig. 4) and torque to specs listed below.

**NOTE:** Check for recommended clearance of starter to:

- Starter to engine and engine components: 4mm minimum
- Starter to body/frame: 25mm minimum
- Starter to heat source (i.e. exhaust manifold): 30mm minimum



**Fig. 5**

## Cable / Wiring Connections

Prior to completing the wiring connections, clean the battery posts and terminals of all battery cables with a wire brush to shiny metal. Check the resistance of the wire cables. B+ battery cable: Battery post to starter solenoid battery terminal (main circuit), 2m Ω max. Battery to solenoid key switch terminal lead (starter control circuit) 13m Ω max.

**NOTE:** If the wiring harness resistance is higher than the above specification, starter engagement problems may occur.

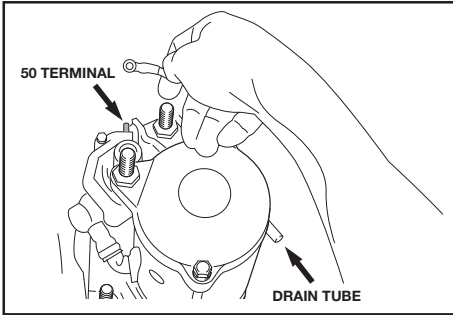
Connect the starter motor cable and solenoid wiring terminals. Tighten the terminal nuts to the following torque specifications. Refer to the wiring schematic diagram to ensure proper connections (See Fig. 5).

- B+ (30 Terminal) 23 - 30 Nm (234.53 - 305.91 kgf•cm, 17.00 - 22.13 lbf ft)
- Negative (Terminal G) 23 - 30 Nm (234.53 - 305.91 kgf•cm, 17.00 - 22.13 lbf ft)
- Key switch (50 Terminal) 2.6 - 4.6 Nm (26.51 - 46.91 kgf•cm, 1.92 - 3.39 lbf ft)

**⚠CAUTION:** Do not over-tighten.

**DENSO**

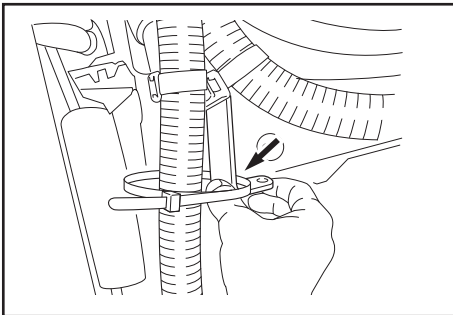
**HEAVY DUTY**



**Fig. 6**

1. Connect the key switch (50 terminal) to the 50 terminal stud on top of the solenoid (See Fig. 6). Note position of the drain tube.
2. Using an 8mm socket, torque to specifications located on page 3.

**△CAUTION:** Do not over-tighten nut. Do not loosen or tighten the securing (lower) nut which holds the original B+(30) terminal extension in place or insulation damage may result. If the B+(30) terminal extension is removed, it must not be reinstalled.



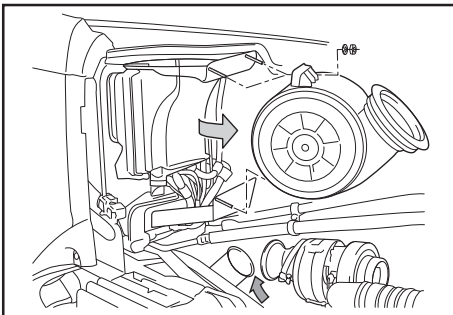
**Fig. 7**

Often, brackets holding battery cables will have to be adjusted to extend the length and reach to the starter.

- Tie wraps may have to be removed or adjusted (See Fig. 7).
3. Retighten all loose brackets.
  4. Secure and tie all cabling that was initially adjusted.

**NOTE:** The bracket adjustments and amount of tie wraps to be removed will vary for each model, model year and engine manufacturer.

## Starter Removal Instructions for Freightliner Chassis with MBE4000 Engine

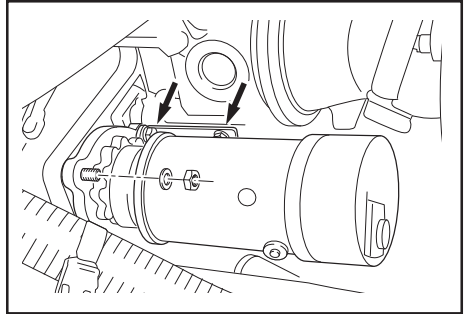


**Fig. 8**

To access the original starter:

1. Remove air filter enclosure and exhaust downstream of the turbocharger (See Fig. 8).

2. The existing starter is located on the passenger side of the vehicle.
3. Take notice of the brass bracket holding the starter in place (See Fig. 9).
4. Loosen the bolts that hold the bracket. Discard the bracket.
5. Loosen all mounting nuts off the studs of the bell housing. Remove the original starter.
6. Proceed to DENSO Starter Installation Instructions shown on page 2.



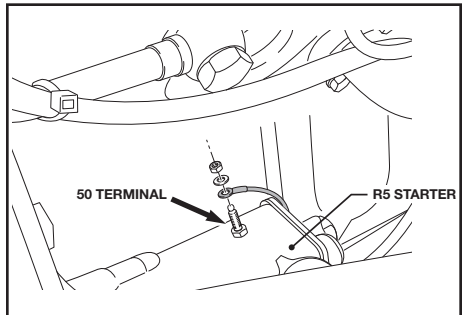
**Fig. 9**

## Special Instructions for Sterling Chassis with MBE4000 Engine

Following the DENSO Starter Installation Instructions shown on page 2;

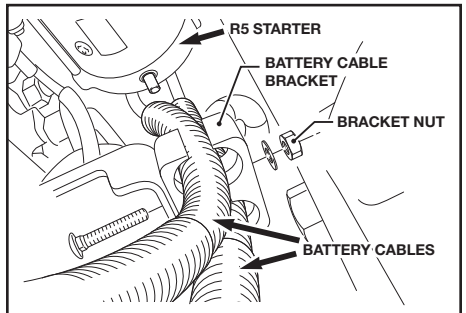
1. Loosen and remove the key switch nut.
2. Connect the key switch wire to the key switch stud (50 terminal) (See Fig. 10).
3. Torque nut to specifications located on page 3.

**NOTE:** If cab is equipped with an engine enclosure, remove the enclosure to access the starter key switch stud (50 terminal).



**Fig. 10**

4. Locate the battery cable bracket attached to the engine block (See Fig. 11).
5. Adjust the cable bracket by loosening the bracket nut.
6. Adjust the positive & negative battery cables towards the starter for proper reach.
7. Secure the cables to the B+(30) terminal and ground stud of the starter.
8. For all installations, torque the B+(30) terminal and ground nuts to specifications located on page 3.



**Fig. 11**

## OCP (Overcrank protection)

- Refer to the OCP bypass section if the vehicle is equipped with OCP (see below).

## Inspection After Installation

1. Check the battery cable terminals for corrosion.
2. Clean if necessary.
3. Reconnect the negative (-) cable to the battery(s).
4. Confirm that the battery is fully charged.
5. Replace any cracked or broken cable insulation with new cable insulation.

## Operation Check

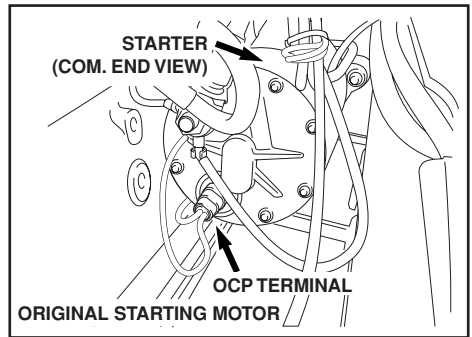
1. Turn key- Start engine and check for proper operation.

## Starting Motor Overcrank Protection (OCP) Circuit Bypass

The OCP circuit is an option used on many trucks. It utilizes a thermal switch to open the starter relay ground circuit when excessive starter temperatures are reached due to prolonged cranking of the starter motor. This is commonly called overcranking.

The information below describes the procedure to bypass the OCP circuit when replacing an OCP equipped starter with a DENSO R5 starter.

The presence of OCP can be identified by looking at the original starter (commutator end view) (See Fig. 12). The OCP terminal comes out of the main wire harness and is plugged into the thermal switch at the rear of the starter. The DENSO R5 kW starter does not require or have an external OCP device. However, it is necessary to complete the relay ground circuit when installing an R5 kW in a vehicle originally equipped with this OCP device.



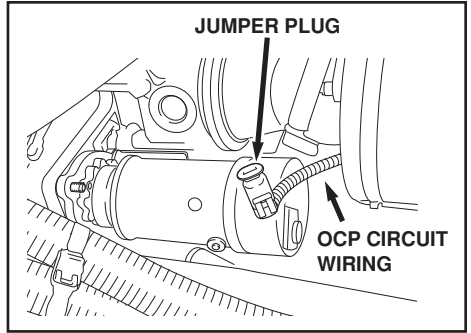
**Fig. 12**

This can be accomplished by installing a jumper plug into the OCP wiring harness connector (See Fig. 13).

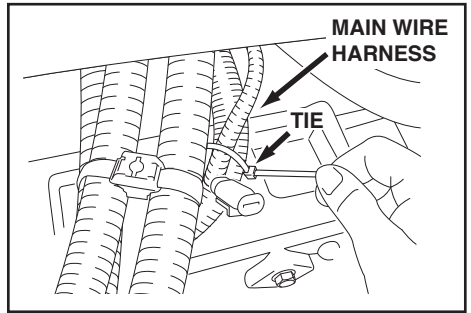
- DENSO OCP Jumper Plug Part #053680-8010
- Tie off the OCP terminal and plug to the main wire harness to prevent separation due to vibration (See Fig. 14).

**NOTE:** An alternate method to complete the ground circuit is to cut the wires at the connector and install a butt connector joining the two wires. Care should be taken to ensure a good connection.

**⚠WARNING:** Failure to do so may result in starter control circuit failure.



**Fig. 13**



**Fig. 14**

For current application updates and photos, please visit [www.DensoHeavyDuty.com](http://www.DensoHeavyDuty.com).

If you have any questions concerning the above information, please call DENSO Technical Support Hotline at (888) 96-DENSO toll free in the United States and Canada or DENSO directly at (310) 834-6352.

---

Para obtener actualizaciones sobre las aplicaciones actuales y fotografías, visite [www.DensoHeavyDuty.com](http://www.DensoHeavyDuty.com).

Si tiene cualquier pregunta referente a la información arriba indicada, llame a la línea de urgencias de Soporte técnico DENSO al (888) 96-DENSO sin costo en los Estados Unidos y Canadá o a DENSO directamente al (310) 834-6352.

---

Pour les mises à jour d'application et photos, visitez le site [www.DensoHeavyDuty.com](http://www.DensoHeavyDuty.com).

Si vous avez des questions concernant l'information ci-dessus, veuillez appeler l'Assistance technique DENSO au (888) 96-DENSO sans frais aux États-Unis et au Canada, ou directement DENSO au (310) 834-6352.

---

3900 Via Oro Avenue, Long Beach, California 90810