

# New Product Announcement

## M125632 Noseless 12 Volt Starter For Cummins ISX / CAT / Detroit Series S60

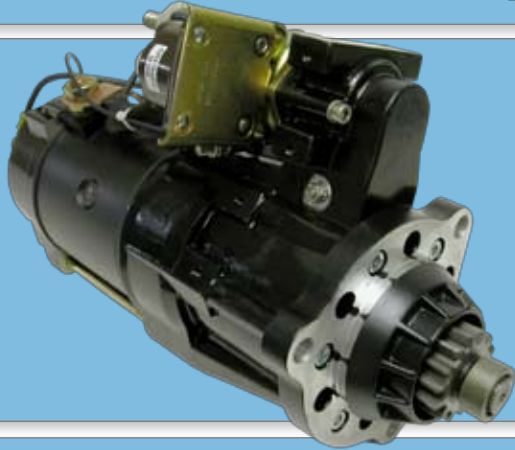

### Titan™125 Extreme Power for Extreme Conditions

- Noseless design fits more applications
- Indexable flange and relay allow for greater versatility with less inventory
- Cummins ISX / CAT / Detroit Series S60
- Dual roller clutch design
- Steel reinforced armatures

### Specifications:

- Noseless design clearance for larger diameter ring gear
- Electrical soft start engagement system
- Diode suppressed
- Indexable relay, Indexable flange
- Approved for wet clutch applications
- O-ring seals on all external studs for water submersion / sealing

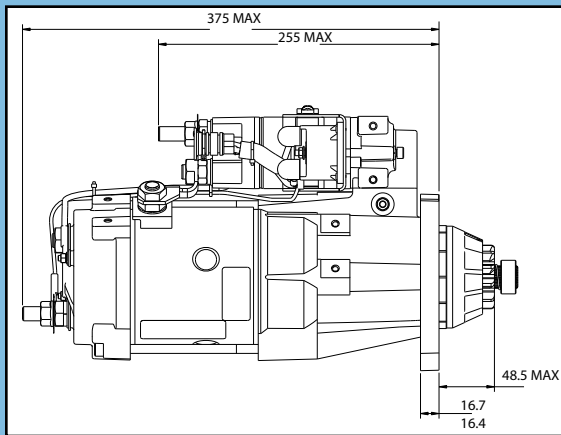

| Part number | Sales # | Engine                                                               | Application Info.                                                                                | Delco    | Denso       | Mitsubishi              | MS2              |                                   |
|-------------|---------|----------------------------------------------------------------------|--------------------------------------------------------------------------------------------------|----------|-------------|-------------------------|------------------|-----------------------------------|
| M125R2632SE | M125632 | Detroit S60<br>Cummins<br>N14,ISM,ISX<br>CAT C11,C12,<br>C13,C15,C16 | Freightliner,<br>Sterling,<br>Western Star,<br>Kenworth,<br>Peterbilt,<br>International<br>Truck | 19011518 | 428000-4420 | IN0976<br>FL057         | PC0979<br>PC1479 | MS2-500D (BYPASS<br>VEHICLE OCP)  |
|             |         |                                                                      |                                                                                                  | 19011521 | 428000-4430 | M009T70579,<br>M9T70579 | PC1879           | MS2-501D                          |
|             |         |                                                                      |                                                                                                  | 19011529 | 428000-4440 | MIB97059                | M983579          | MS2-503D                          |
|             |         |                                                                      |                                                                                                  | 19011530 |             | MIB70579FL              | 20851006         | MS2-503ND                         |
|             |         |                                                                      |                                                                                                  | 8200050  |             | 8MJ5439M<br>MK0077      | VV0776           | MS2-504D (BYPASS<br>VEHICLE OCP)  |
|             |         |                                                                      |                                                                                                  | 8200090  |             | 009T70077,<br>8MJ4298AM |                  | MS2-504ND (BYPASS<br>VEHICLE OCP) |
|             |         |                                                                      |                                                                                                  | 8200091  |             | VV0977<br>MIB970975     |                  | MS2-510D (BYPASS<br>VEHICLE OCP)  |
|             |         |                                                                      |                                                                                                  | 8200104  |             | MIB970975FL<br>FL0975   |                  | MS2-510ND (BYPASS<br>VEHICLE OCP) |
|             |         |                                                                      |                                                                                                  | 8200289  |             | MIB970777               |                  | MS2-511D                          |
|             |         |                                                                      |                                                                                                  | 8200290  |             | MIB970777FL             |                  | MS2-511ND                         |
|             |         |                                                                      |                                                                                                  | 8200308  |             | FL0777                  |                  |                                   |
|             |         |                                                                      |                                                                                                  | 8300009  |             | D61-6002-004            |                  |                                   |
|             |         |                                                                      |                                                                                                  | 8300019  |             | D61-6002-008            |                  |                                   |

Note: In some instances the starter flange may need to be relocked and vehicle OCP circuit bypassed with furnished bypass plug.

All M125R starters have IMS/ soft start relay.

\* NOTE: this table cross references the 39MT only. For cross references to 42MT and 50MT, please go to our website at [www.prestolite.com](http://www.prestolite.com)

For more information  
contact your sales representative

Prestolite  
Leece-Neville

Marketing Information