

44MT™

HEAVY DUTY STARTER 12V/8.5kW
Every start. Every time.



A POWERFUL LEGACY | *Engineering the Future™*

44MT™

**Packed with power & patented features
in a compact & lightweight design.**

**You can actually hear and feel
the difference when you crank the engine.**

Trucking
'11 Top 20

**Winner of the 2011
Heavy Duty
Trucking
Best of the Best Award**

With engine changes due to emission standards and anti-idling regulations, engines are harder to crank and require more starts per day than ever before. Extreme engine conditions and frequent starts and stops require a starter that is more robust and durable.

The Delco Remy 44MT gear reduction starter addresses all of these issues and more. It delivers with its increased cranking power, durability, and extended life cycle all in a compact, lightweight self-contained design.

INSTALLATION SIMPLIFIED

- No exposed wiring or additional mounting brackets required
- Reduced customer wiring harness complexity
- Removes connection points, reducing corrosion
- Rotatable nose housing reduces service part numbers

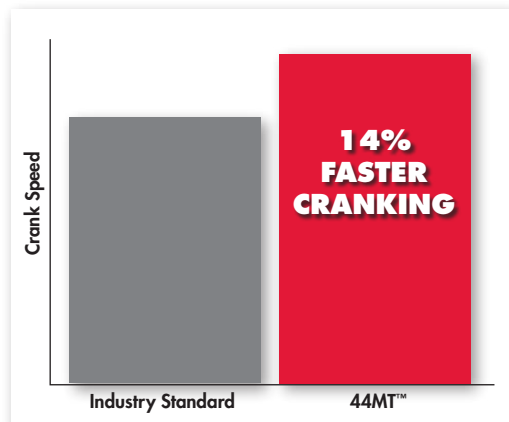

Test Conditions

- Big bore engine
- 0°F (-17.8°C)
- 70% battery state of charge

Results

- Reduced pinion & ring gear wear
- Less overall battery draw



PATENTED TECHNOLOGIES MEAN PEAK PERFORMANCE

ENHANCED STARTER RELIABILITY Internal Magnetic Switch Solenoid (IMSS)

- Patented one wire design integrated inside the solenoid
- Eliminates environmental issues and contamination
- Input current is capable of ECM control
- Withstands engine temperatures up to 120°C/248°F
- Simplified troubleshooting and maintenance

MAJOR DRIVE LIFE IMPROVEMENT Clutch Over Planetary Gear Drive System (COPG)

- Patented design delivers the high demand torque of big bore engines
- Improved electrical soft start engagement slowly rotates the pinion until it is properly engaged to the ring gear before cranking
- Reduces engagement milling and teeth abutments (click/no crank), resulting in improved reliability
- Extends ring gear life

ELIMINATES THE NEED FOR VEHICLE WIRING HARNESS Integrated Over Crank Protection (OCP)

- OCP, a built-in circuit breaker, protects the starter from thermal damage, automatically resetting at safe operating temperatures
- New self-contained, one-wire design with no additional connections required, completely eliminates the need for a special vehicle wiring harness

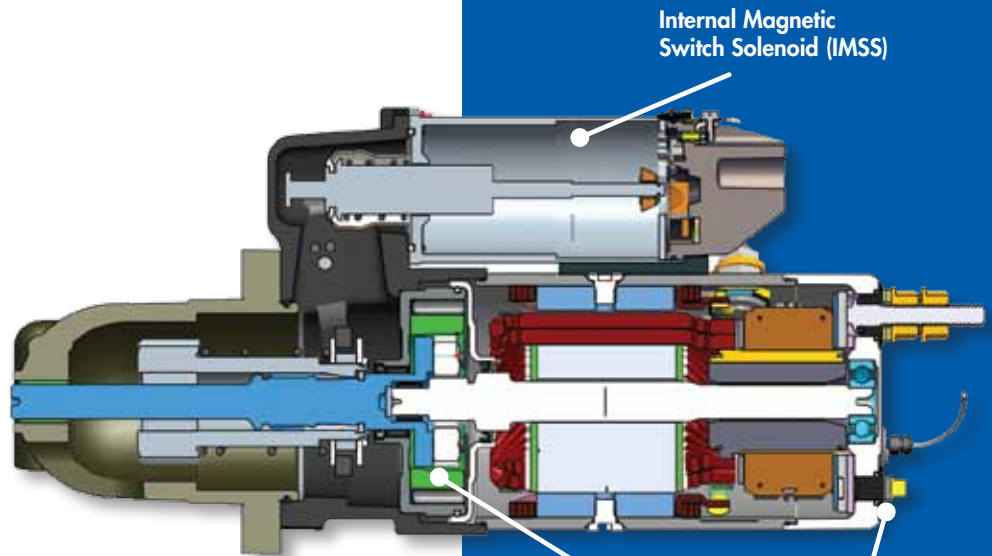

Internal Magnetic Switch Solenoid (IMSS)

Clutch Over Planetary Gear Drive System (COPG)

Integrated Over Crank Protection (OCP)

SPECIFICATIONS

44MT™

Engine Size	up to 16 liter
Rotation	Clockwise
Mounting	SAE #1, SAE #3
Pinion Data	SAE: 11 Tooth, 6-8 Pitch SAE: 12 Tooth, 8-10 Pitch SAE: 12 Tooth, Mod 3-metric
Output	8.5kW peak at 12V
Weight	17.7 kg / 39.0 lbs
Diameter	115 mm / 4.53 inches

COMPETITIVE SIZE & POWER COMPARISON

Starter Model	Overall Length (mm)	Diameter (mm)	Weight (kg)	Power Rating (kW)
Delco Remy 44MT™	437	115	17.7	8.5
Delco Remy 39MT™	417	115	14.7	7.3
Denso R5	325	100	10.7	5.0
Leece Neville Titan M125	443	144	18.1	8.0
Mitsubishi 105	403	105	13.0	6.0

WARRANTY
4 year
440,000 miles

Cross Reference

OEM	Engine	Pinion Pitch / Teeth	44MT Part #	39MT OE Part #	39MT Rotatable Flange Part #	Mitsubishi 105	Leece Neville Titan 125
Freightliner Sterling Western Star	MBE 4000	Mod 3 metric 12 tooth	8200771	19011514	8200434	MIB971179, MIB971179FL FL1179	N/A
				19011525			
				8200082			
				8200084			
	Cummins ISC, ISL	8/10 - 12 tooth	8200770	19011517	8200433	N/A	N/A
				19011526			
				8200087			
				8200081			
	CAT C15 Cummins ISX, ISM, M11 Detroit S60	6/8 - 11 tooth	8200750	19011518	8200308	MIB970975, MIB970975FL, FLO975, MIB970777, MIB970777FL, FLO777, FLO579	M125601
				19011530			
				19011521			
				8200091			
Detroit DD15/13	Mod 3 metric 12 tooth	8200771	8200329	8200434	N/A	N/A	
			8200298				
Navistar	Cummins ISX, ISM, M11 CAT C11, C13, C15, C16	6/8 - 11 tooth	8200750	8200050	8200308	3815734C91 IN1478	M125601
				8200091			
	DT466 DT570 HT570 Maxforce DT, 9, 10	8/10 - 12 tooth	8200770	8200081	8200433	MITIN1378	N/A
				8200218			
MaxForce 11/13	8/10 - 12 tooth	8200770	8200219	8200433	3667911C91, IN2178	N/A	
			8200360				
Kenworth Peterbilt	CAT C9, C10, C11 C12, C13, C15, C16 Cummins ISX, ISM, M11	6/8 - 11 tooth	8200750	19011529	8200308	D61-6002-004, D61-6002-008, PC0979, PC1479, PC1879 M983579	M125601
				8200050			
				8200090			
				8200104			
Mack	Mack E7	6/8 - 11 tooth	8200750	19011500	8200308	MK0077	M125601
				19011505			
				19011531			
				8200037			
	Mack MP7	8/10 - 11 tooth	N/A	8200223	N/A	21001797, MK1075	N/A
Mack MP8	8/10 - 12 tooth	8200770	8200214	8200433	21019460, MK2078	N/A	
			8200572		21019460, MK2079	N/A	
Mack MP10			8200182		21045969	N/A	
Volvo	Volvo D12	8/10 - 12 tooth	8200770	19011515	8200433	WV0279	N/A
				8200186			
				8200058			
	Cummins ISX, ISL	6/8 - 11 tooth	8200750	19011516	8200308	20851006, WV0776, WV0977	M125601
				19011530			
				8200091			
	Volvo D11	8/10 - 11 tooth	N/A	8200223	N/A	21001781, W1076	N/A
	Volvo D13	8/10 - 12 tooth	8200770	8200214	8200433	21019456, W2079	N/A
8200572				21019456, W2080		N/A	
Volvo D16			8200182		21001825, W1979	N/A	

Remy Inc. is a leading global manufacturer of Delco Remy brand heavy duty starters and alternators, light duty starters, and electric motor technology for EV and hybrid vehicles. A powerful legacy for over 100 years, today Remy International is engineering the future of the vehicle industry.



delcoremy.com

Remy Inc.
600 Corporation Drive
Pendleton, IN 46064 USA
For Technical Assistance call 1-800-372-0222

Delco Remy is a registered trademark of General Motors Corporation, licensed to Remy Inc., Pendleton, IN 46064
PRINTED IN USA | C11131